

Drill rig

BS 630N

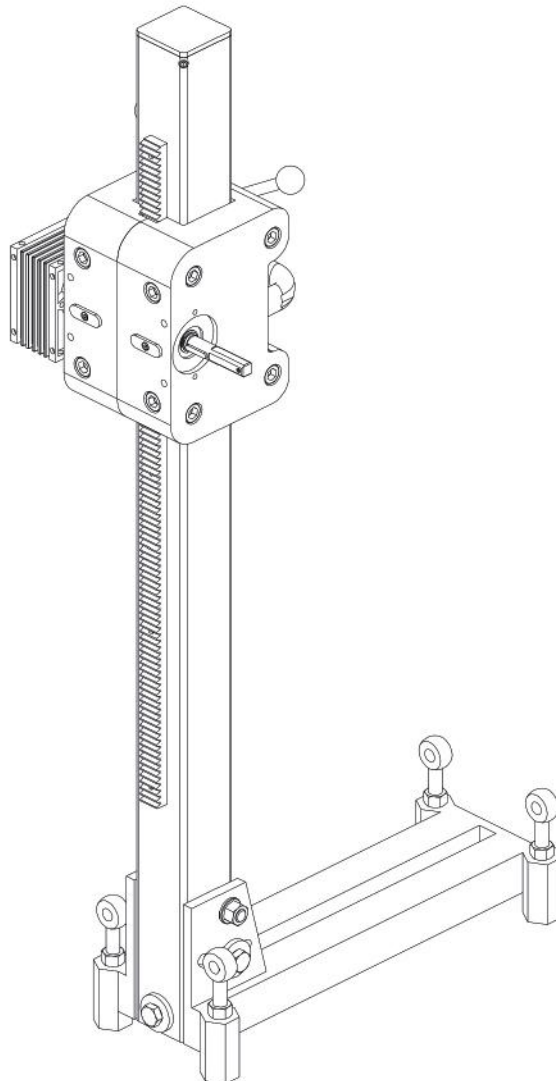

KERN-DEUDIAM
Diamantwerkzeuge und Maschinen GmbH

Tel. +49 5257 507-0 Industriestraße 24
Fax +49 5257 507-40 33161 Hövelhof
kern-deudiam.de | info@kern-deudiam.de



Please read these instructions carefully before starting up the machine!

1. Table of contents

1. Table of contents	2
2. General Information	2
3. Work- and safety- instructions	3
4. Technical Data	4
5. Operative range and determined application	5
6. Connection and Assembly	5-8
7. Initiation	9
8. Maintenance	10
9. Customer Service	10

2. Introduction

With this drillstand type **Bs 630N** you have purchased a top class machine. What makes this product out stand are reliable operation, easy handling and high mobility due to the application of new technologies and permanent improvement of quality.

The complete operating manual should be kept close to place of application. Particularly important details for the application of the bench saw are emphasised in this operating manual. Therefore it is important, that the persons responsible should be familiar with the manual. We are not liable for any damage or interference caused by not observing the instructions

2.1. General Information

In the further text the operating manual is marked as **BA**. Besides this, the following abbreviations are used:

Abb.	- illustrations
Tab.	- table
ND	- not shown
ETL	- list of spare parts

2.2. Used symbols



This symbol will be found at all work- and safety- instructions in this manual, where danger exists to body and life of person. Read these notice and take particular care in these cases.

Attention

This symbol will be found where special attention is to be paid, so that instructions, notices and the correct sequence of work is kept and also to prevent damage or destruction of the machine and other parts

3. Work-and safety- instructions

The drill stand has been built corresponding to the latest technics and safety requirements. Dangers can arise if operated by non qualified persons or used for non determined application.

Every person in the works of the user, who are familiar with the operating, maintenance and servicing of the drill stand, must read the complete operating manual s and in particular the Safety instructions. These must be understood. It is recommended that the user receives a written confirmation of this

Included in determined application is the adherence of the manufactures specified assembly, disassembly, setting into operation and maintenance conditions.

The drill stand may only be operated and maintained by authorised, trained and instructed persons. These persons must be informed of any dangers that may occur

Every work method is forbidden, which could endanger safety. The operator is also responsible if non-unauthorised persons work with the machine.

The operator is obliged to report any alterations to the machine which could endanger safety immediately.

The operator is also obliged only to operate the drill stand when it is in flawless condition.

It is not permitted to make any alterations to the machine which could endanger safety.

Keep work area clean. Cluttered areas and benches lead injuries.

All maintenance work on the machine is to made while the machine is still and with core drill machine switched off.

Dress properly. Do not wear loose clothing. They can be caught in moving parts. Rubber gloves and non- skid footwear are recommended when working outdoors.

Keep proper footing and balance at all times.

Maintain tools with care. Keep tools sharp and clean for better and safer performance. Check damaged parts.

Disconnect tools when not in use, before servicing and when changing accessories such as core drills and spare parts.

Works on electrical facilities must only be executed by skilled workers or especially instructed persons under guidance and supervision of a skilled worker corresponding to the electrotechnical rules.

It is not permitted to drill overhead without the water collecting device.

The operator must wear ear protectors when the drill is in operation.



Do not transport thr drill stand with a crane hook!

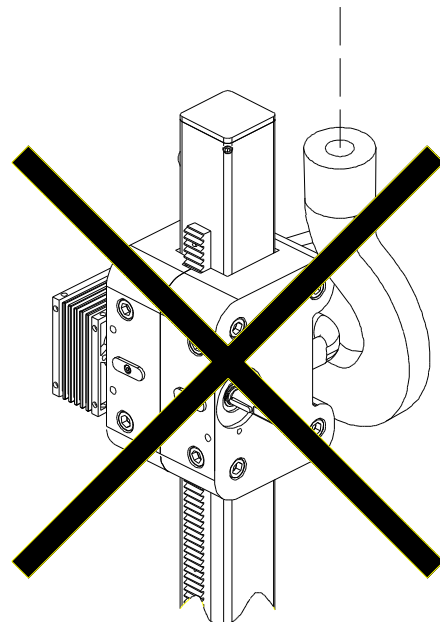

4. Technical data

Machine description:	drill stand
Machine type:	BS 630N
Machine-No.:	
Weight:	22 kg
Drill diameter:	400 mm 625
Stroke:	mm
Gear box (Reduction rate)	1:5,25(1:1)
Guide	
column tilt:	0-45°

4.1. Dimensions

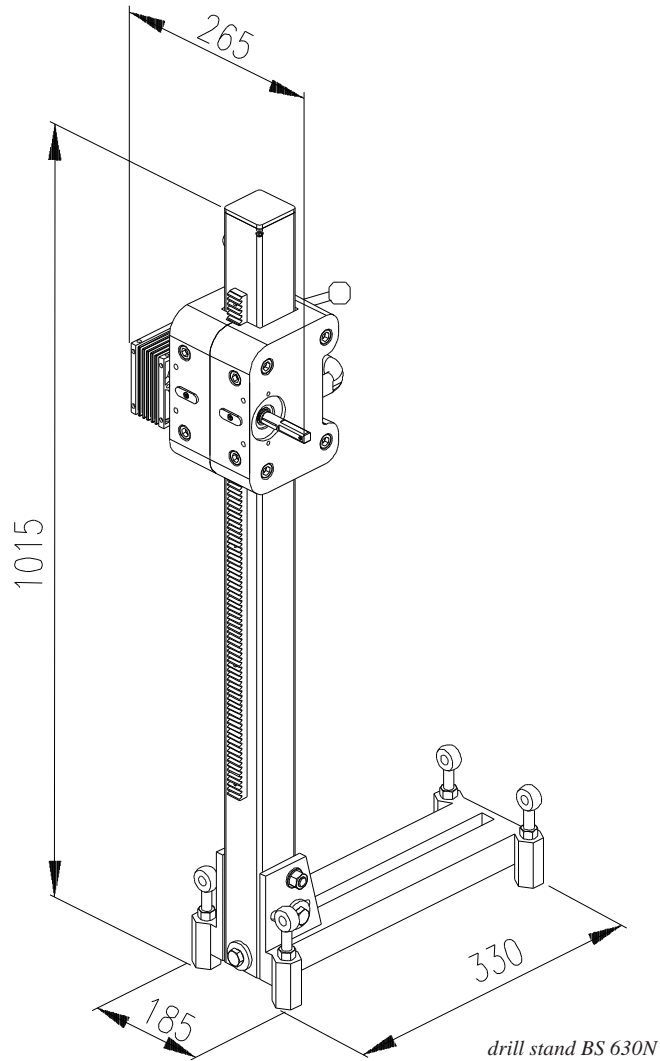

5. Operative range and determined application

The drill stand type **BS 630N** is exclusively designed for production of core drill holes up to **400 mm** in concrete, brickwork or similar building materials. Any other application other than this is valid as a non-determined application.

According to illustrations and information given in this manual, we reserve the right of technical changes in order to improve the drill stand

6. Connection and Assembly

6.1. Fastening the base plate

The anchor hole is to be drilled approx. 350 mm from the centre of the drill hole. Fasten the base in this exact position.

To ensure a sufficient fixture only M12 heavy-duty anchors or M12 hammered anchors are to be used.

The recommended load should not be less than 4.5kN. Please consider the instructions of the manufacturer. After the base plate has been secured, the adjusting screws are to be tightened until the base plate is firm on the ground.

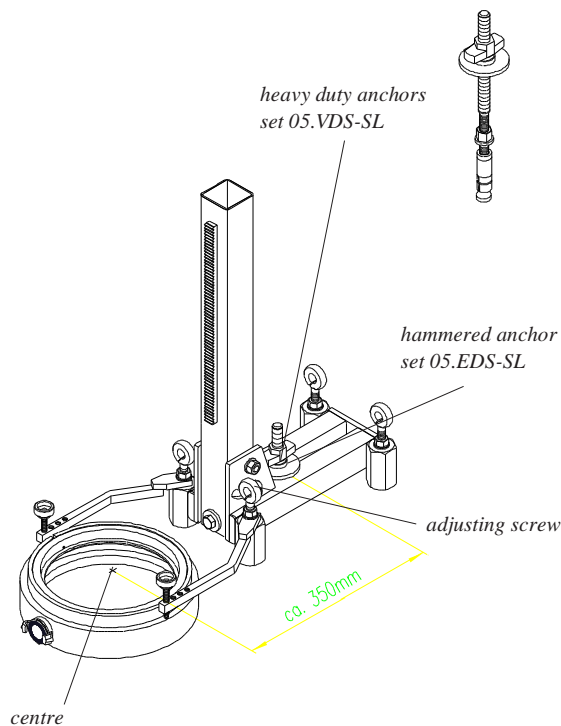

2. Fastening the base plate using vacuum plate (option)

First the vacuum plate is to be fastened under the base plate using the wing nut, then screw the adjusting screws right back. Couple the hose to the vacuum plate.

Using the vacuum pump start to press down. A pressure of -0,9 to 0,7 bar provides for a sufficient vacuum for a safe fastening. As this type of fastening depends on the consistence of the ground, it can only be fastened to a relative smooth, flat and non-porous surface. Once a vacuum of between -0,9 and 0,7 bar has built up, the adjustment screws are to be screwed out until the vacuum plate is stable. Additionally the drill stand is to be secured against falling down, e.g. with a rope.

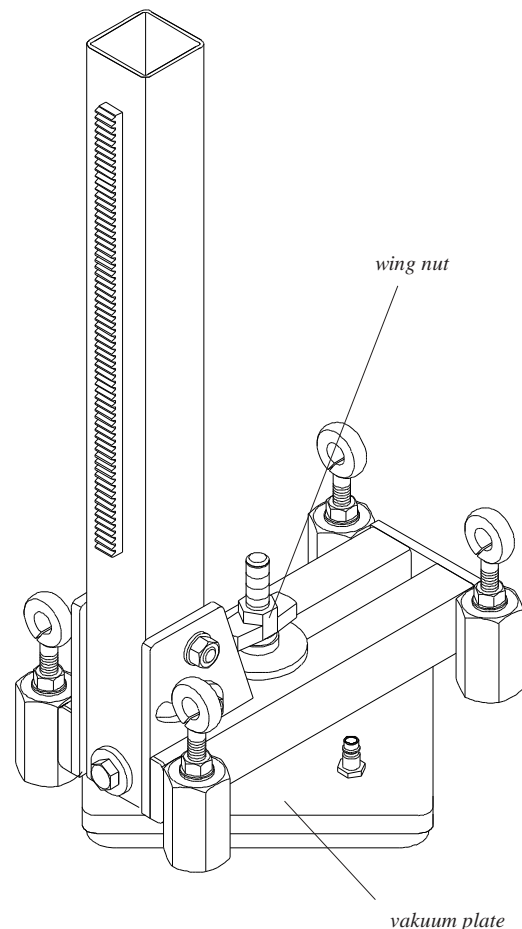

Attention

Fastening by means of a vacuum is not suited for ceiling drilling (overhead).

6.3. Adjusting the column angle 6.5. Mounting the gearbox

To carry out core drilling at a certain angle, the forward hexagon screw is removed. Then loosen the two hexagon screws and nuts on both sides. Now swivel the guide column into the required position and fasten the hexagon screws and nuts again.

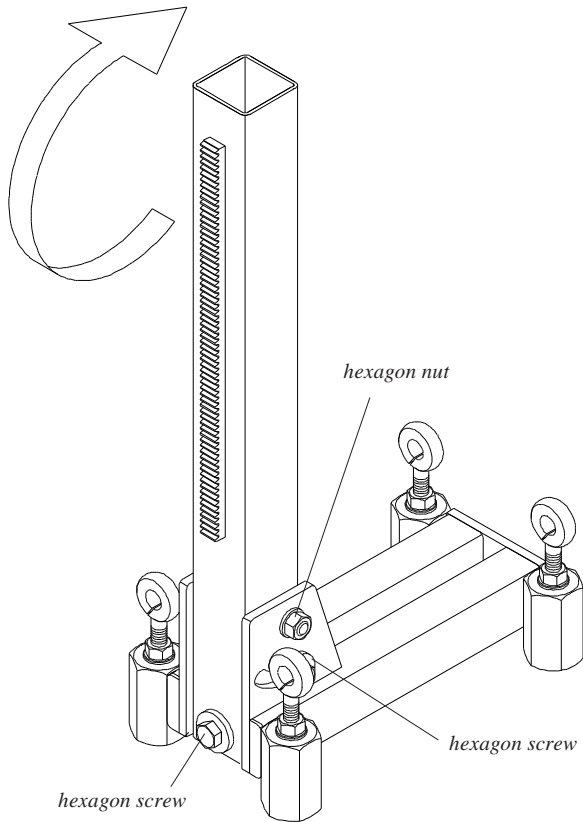

6.4. Fastening the rollers at the base plate

Fasten the rollers with two socket had cap screws by using a socket wrench shown on the figure below.

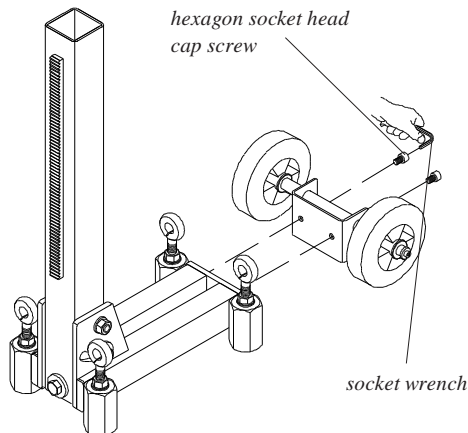

Push the gearbox onto the shaft and fastening it with the hexagon socket head cap screw. You can fasten the gearbox from both sides, also the cross handle.

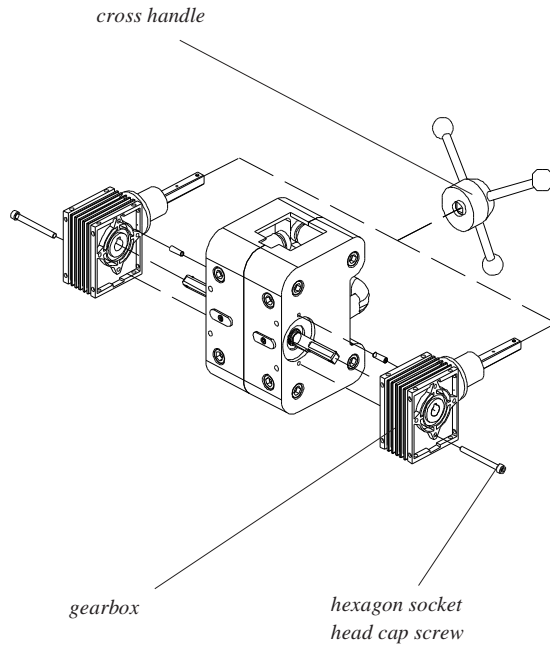

6.6. Fastening the core drilling machine at the drill stand

6.6.1 Fastening the mounting plate 20 mm, 60 mm

Fastening the core drilling machine at the motor mounting plate with four socket had cap screws.

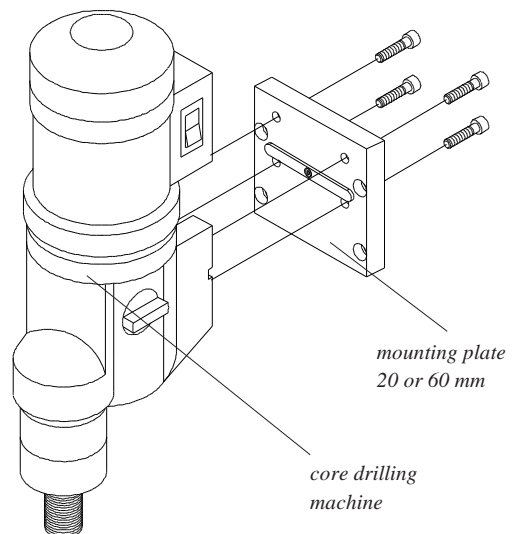

Then fasten the assembled unit onto carriage with four socket had cap screws.

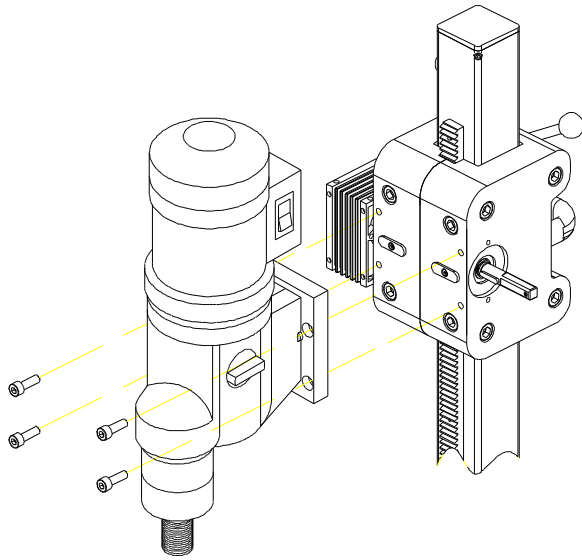

6.6.2 Fastening with the quick clamping device MSK

First fastening the core drilling machine at the motor mounting plate with four socket head cap screws. The assembled core drilling machine placed upon the parallel straight pins. Then turn the machine to the guide column and fasten it with the hexagon nut.

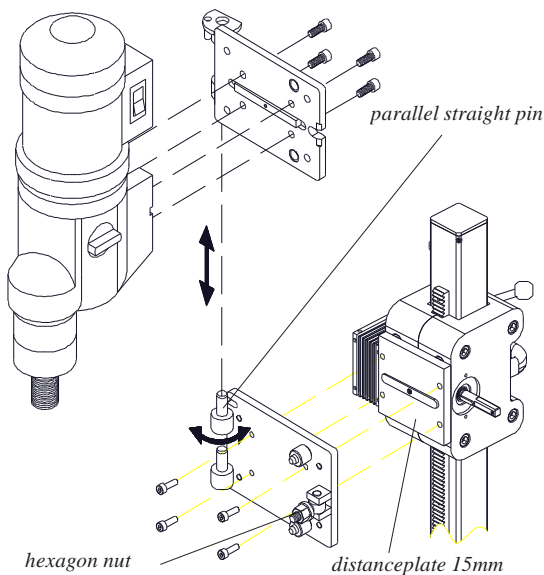

6.7. Fastening the water collection device

First lay the water collecting ring under the drill bit. Run the carriage with the tool down so that the water collecting ring can be centralised.

Now the two nuts on the base plate are to be turned up, the holder is now to be pushed under the nuts. Adjust the holder parallel to the base plate and tighten with the nuts. The water collecting ring should keep approx. 2 mm range between the holder .

Using the two clamping screws the water collecting ring is pressed to the ground and fixed. The cooling water can be drained or sucked away at the coupling.

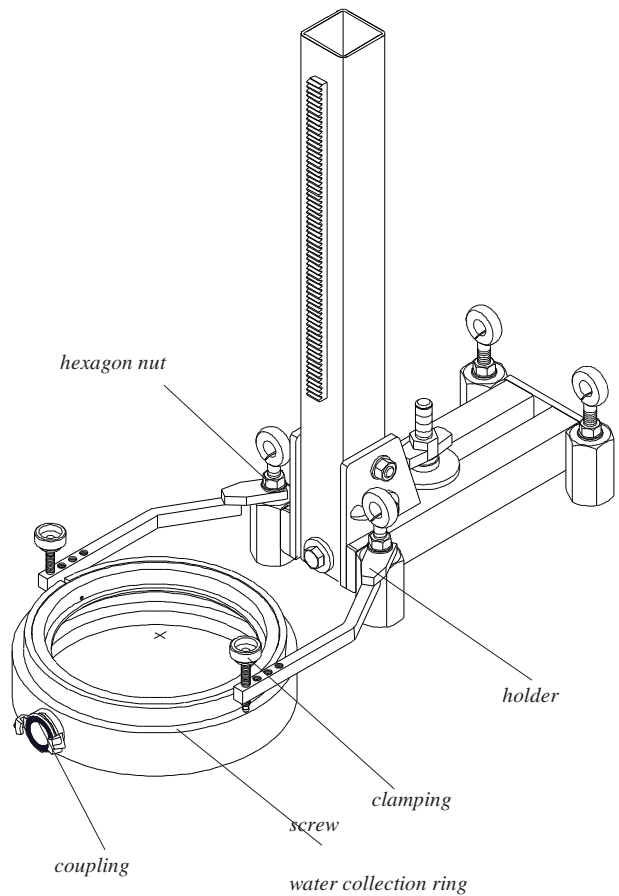

6.8. Electrical connection

6.8.1 Connecting A.C. motors

The electrical connection of core drilling machines must be effected via a residual current circuit-breaker (RCD, PRCD). For there more, such machines may only be operated with properly earthed socket outlets. The rated current, i.e. fault current at which the circuit-breaker will switch off, is 30 mA.



Do not operate a core drilling machine without RCD/PRCD!

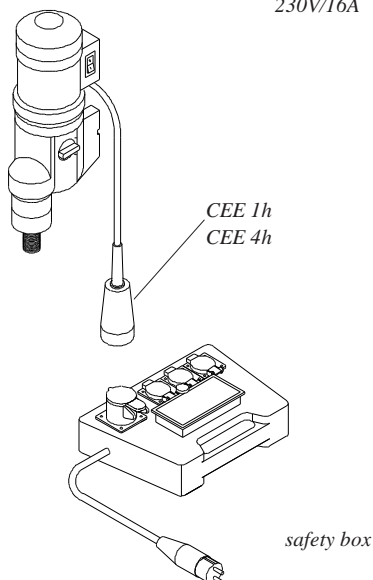
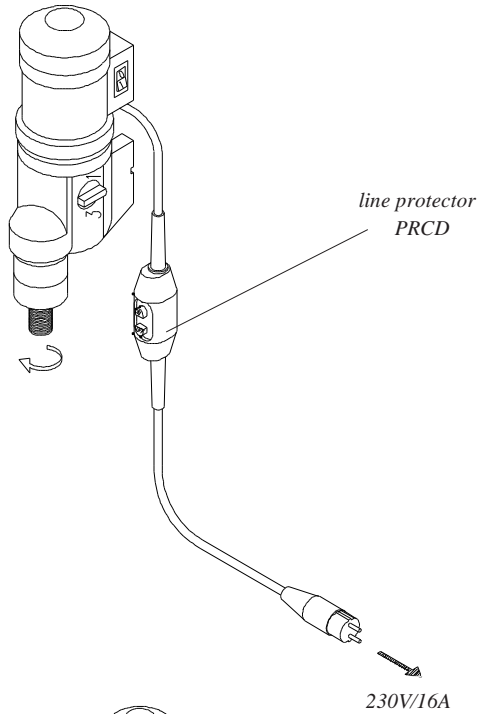

6.8.2 Connecting threephase current motors

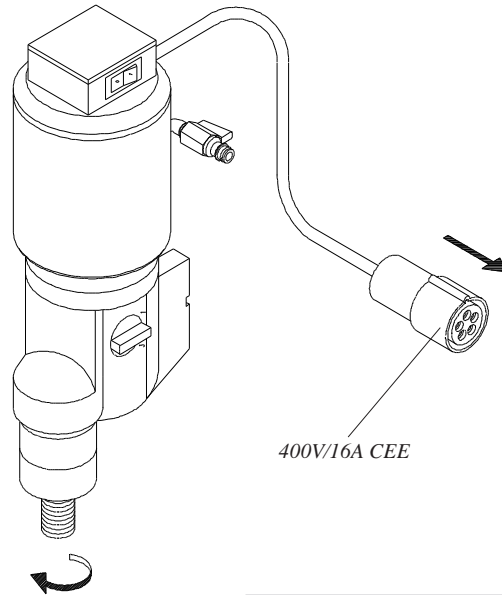

Attention

*Pay attention to the right direction of the core drilling machine!
Change the direction by turning the Phase inverter!*

6.9. Cooling water connection

Connect the core drilling machine via plug-in nipple by using a GARDENA coupling.

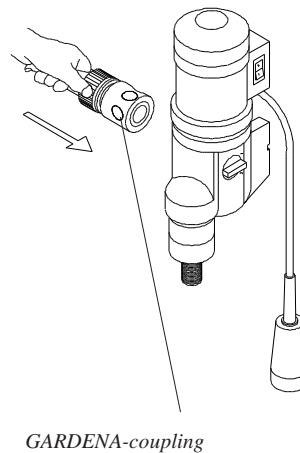

Attention

Use only clean water!

7. Initiation

Select the right speed at the core drilling machine (Note the Instruction Plate).

Put a bronze washer between tool and spindle

Open the stop valve for cooling water. Then start to operate.

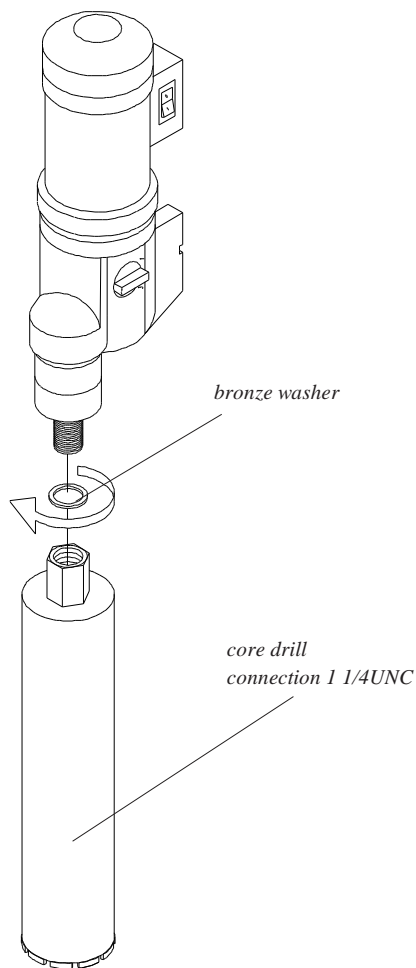

Attention

Note the operating instructions and manufactures details of core drilling machines, tools and accessories.

The feed is carried out with a crosshandle which can be pushed onto either end of the shaft.

The carriage is retained by a knurled screw.

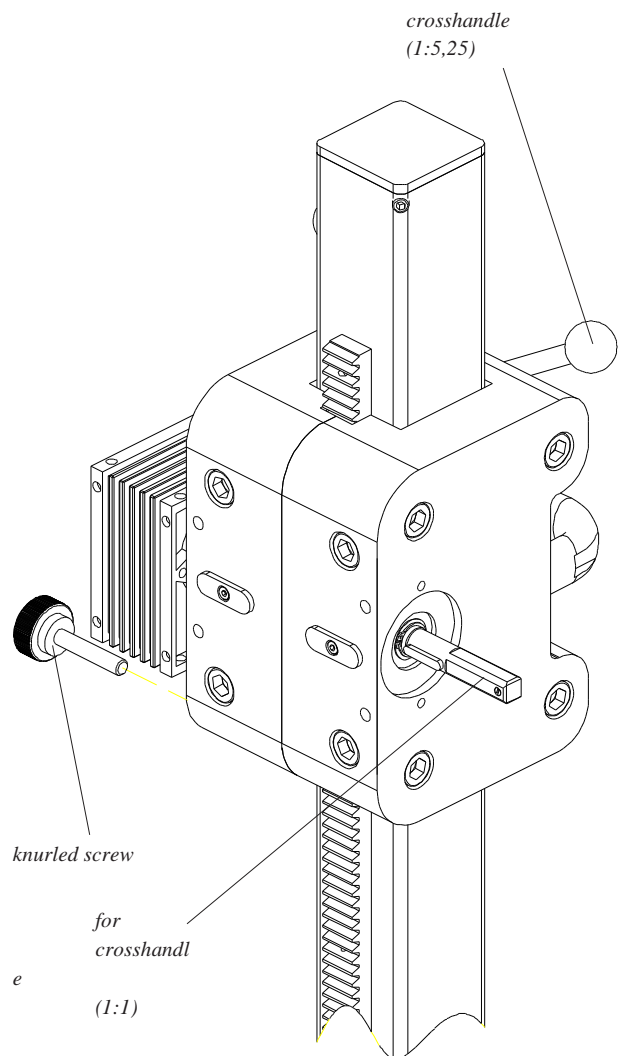

A water collecting device is to be used when drilling overhead.

8. Maintenance

Read operating safety instructions when carrying out maintenance work.

Disturbances caused by a insufficient or improper maintenance can lead to high repair costs. Regular maintenance is there for essential.



*Disconnect tools before servicing.
Be certain that the carriage cannot
move down.*

The following maintenance work should be held:

Clean the bench saw after every working day,

visual inspection for leakage at the core drilling machine, check seals and spindle exchange damaged parts at leakage tighten the gearbox

check electrical parts for damage, exchange damaged cables and plugs

after 50 working hours fetten, grease the toothed rack keep clean and oil slightly the guide column oil or lubricate slightly Hexagon screws at the base plate

check seals at the water Collecting device and vacuum plate, exchange damaged seals.

11. Customer service

For the permanent function of the machine a regular maintenance is absolutely necessary. To order spare parts refer to the attached spare parts list. For further information refer to the assembly drawings listed in the parts list.

The application of any parts not supplied by us. can under circumstances, alter the given constructive characteristics of the wall saw and could have influence on the active and/or passive safety **DEUDIAM Diamantwerkzeuge und Maschinen**

GmbH cannot be made liable for any damage caused by spare parts they have not supplied.

To guarantee a fast delivery of your order and avoid any wrong delivery, the following details are absolutely necessary with every order of spare parts.

1. Machine type according to data plate
2. Fabr.-Nr. according to data plate
3. Number of article according to spare parts list
4. desired quantity of spare parts

KERN-DEUDIAM Diamantwerkzeuge und Maschinen GmbH

Industriestraße 24

D-33161 Hövelhof

Germany

Telefon +49 (0) 5257-5070

Fax +49 (0) 5257-50740

www.kern-deudiam.de

info@kern-deudiam.de



